

MultiSync® XG135LC Distance Chart

With Standard HD-18 Lens

9.1.97

Contents

Notes and Formulas	Page 1
Projection Distance and Screen Size for Ceiling Mount	Page 2
Projection Distance and Screen Size for Desktop	Page 3
Projection Distance and Screen Size for Rear Projection	Page 4
Cabinet Dimensions	Page 5
Cabinet Dimensions (Front View)	Page 6
Projector Mounting Locations	Page 7
Standard Ceiling Mount and Bracket	Page 8
Deluxe Ceiling Mount and Bracket	Page 9

Notes

- For screen sizes of 60 to 300 inches not indicated on the projection tables, use the formulas below.
- The projection distance is based on the screen width.
- If the figures on the table do not match the figures in the formulas, use the figures in the table.
- The margin of error for projection distance (A) is ±3%.
- For screens 150 inches (3810 mm) or larger (in the diagonal direction), set so that the distance between the surface of installation of the mounting A and the ceiling is E.

Formulas

Units: Inches, W"=Horizontal Screen Width

$$A = [(25/96 \times W" - 12.5) \times 5.47] + 71.85$$

$$B = (\beta \times A) + 10.83$$

$$C = \gamma \times A$$

$$D = (\beta \times A) + 10.04$$

$$E = (\frac{1}{2} \times \text{Screen Height}) - B$$

Units: Millimeters, W"=Horizontal Screen Width

$$A = [(25/96 \times W" - 12.5) \times 141 + 1825$$

$$B = (\beta \times A) + 275$$

$$C = \gamma \times A$$

$$D = (\beta \times A) + 245$$

$$E = (\frac{1}{2} \times \text{Screen Height}) - B$$

- A** Distance between the lens and the screen center
- B** Distance between the top of the supplied ceiling mount bracket and the screen center
- C** Distance between the screen surface and the lens
- D** Distance between the desktop and the screen center
- E** Distance between the ceiling and the top of the supplied ceiling mount bracket

Screen Size (Diagonal)	α	β
60-79°	11.8°	0.204
80-129°	12.2°	0.211
130-179°	12.4°	0.215
180-300°	12.6°	0.218

MultiSync® XG135LC Distance Chart

With Standard HD-18 Lens

9.1.97

Projection Distance and Screen Size for Ceiling Mount for XG135LC

Install in such a way that the projector and screen are positioned in the proper direction and at the proper angle. If not, the projector's performance will be affected and its reliability will decrease. Be sure to position the projector properly. The manufacturer will not be held responsible for any problems occurring when the projector is not installed in the proper position.

The following shows the proper relative positions of the projector and screen. Refer to the table to determine the position of installation.

Ceiling Mount System

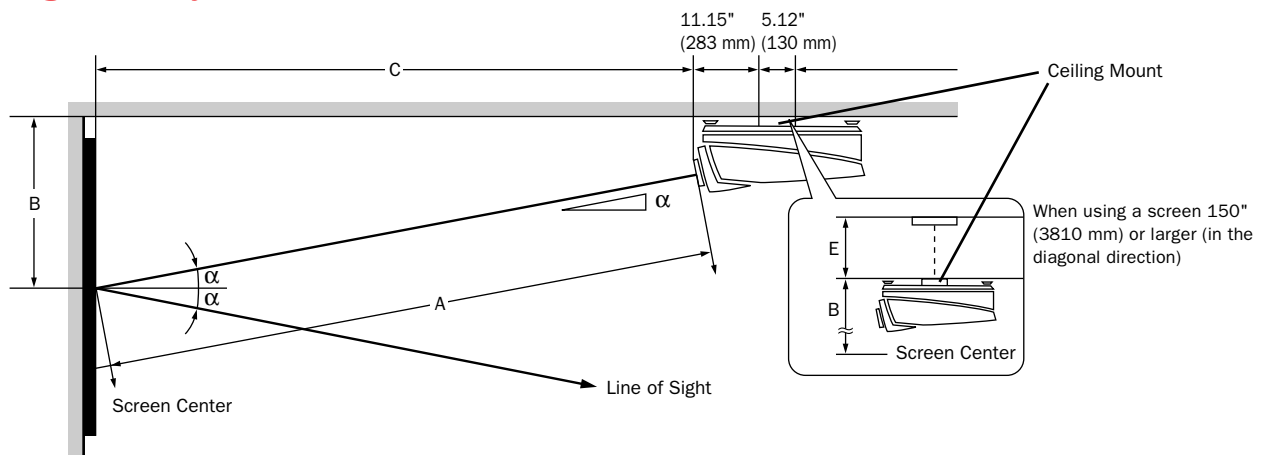

α		11.8°		12.2°		12.4°		12.6°					
β (=sin α)		0.204		0.211		0.215		0.218					
γ (=cos α)		0.979		0.977		0.976		0.976					
Screen Size H-Width		48"	56"	64"	72"	80"	96"	120"	144"	160"	192"	216"	240"
(4:3 Diagonal)		(60")	(70")	(80")	(90")	(100")	(120")	(150")	(180")	(200")	(240")	(270")	(300")
A	inch	71.10	82.83	94.61	106.34	118.07	140.91	175.16	209.57	232.48	278.15	309.17	338.62
	mm	1806	2104	2403	2701	2999	3579	4449	5323	5905	7065	7853	8601
B	inch	25.38	27.78	30.18	33.31	35.79	40.61	48.45	56.55	61.55	71.51	78.28	84.70
	mm	645	705	767	846	909	1032	1231	1436	1563	1816	1988	2151
C	inch	69.61	81.10	92.62	103.89	115.36	137.66	171.13	204.54	226.90	271.47	301.75	330.50
	mm	1768	2060	2353	2639	2930	3497	4347	5195	5763	6895	7665	8395
E	inch	—	—	—	—	—	—	—	—	—	0.47	2.72	5.28
	mm	—	—	—	—	—	—	—	—	—	12	69	134

Note:

For screen sizes of 60 to 300 inches not indicated on the projection tables, use the formulas on page 1. All calculations are with standard lens HD-18.

MultiSync® XG135LC Distance Chart

With Standard HD-18 Lens

9.1.97

Projection Distance and Screen Size for Desktop for XG135LC

The following shows the relative position relationship of the projector with the screen. See table below.

Desktop System

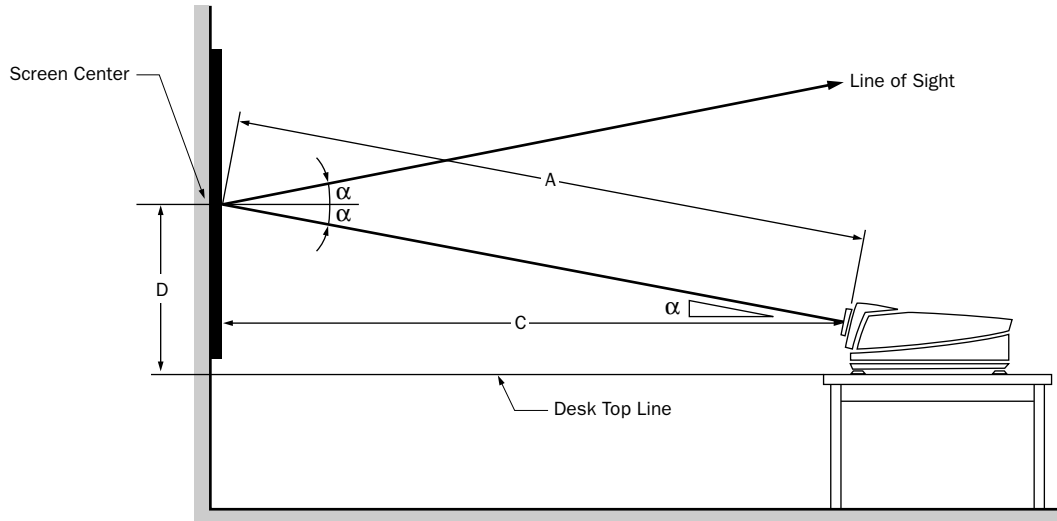

α	11.8°	12.2°					12.4°	12.6°					
β (=sin α)	0.210	0.215					0.218	0.220					
γ (=cos α)	0.978	0.977					0.976						
Screen Size H-Width	48"	56"	64"	72"	80"	96"	120"	144"	160"	192"	216"	240"	
(4:3 Diagonal)	(60")	(70")	(80")	(90")	(100")	(120")	(150")	(180")	(200")	(240")	(270")	(300")	
A	inch	71.10	82.83	94.61	106.34	118.07	140.91	175.16	209.57	232.48	278.15	309.17	338.62
	mm	1806	2104	2403	2701	2999	3579	4449	5323	5905	7065	7853	8601
C	inch	69.61	81.10	92.62	103.89	115.36	137.66	171.13	204.54	226.90	271.47	301.75	330.50
	mm	1768	2060	2353	2639	2930	3497	4347	5195	5763	6895	7665	8395
D	inch	24.20	26.59	29.00	32.13	34.61	39.43	47.27	55.37	60.37	70.33	77.10	83.52
	mm	615	675	737	816	879	1002	1201	1406	1533	1786	1958	2121

Note:

For screen sizes of 60 to 300 inches not indicated on the projection tables, use the formulas on page 1.
 All calculations are with standard lens HD-18.

MultiSync® XG135LC Distance Chart

With Standard HD-18 Lens

9.1.97

Projection Distance and Screen Size for Rear Projection for XG135LC

The following diagram shows the relationship between projector position and the screen. See table below.

Rear Projection System

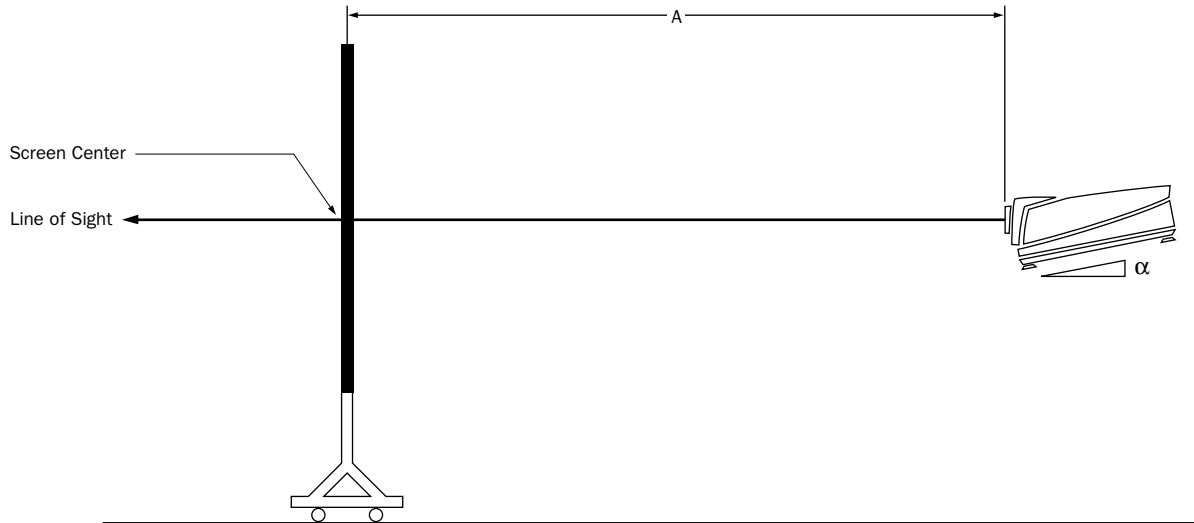

α	11.8°		12.2°				12.4°	12.6°					
$\beta (= \sin \alpha)$	0.210		0.215				0.218	0.220					
$\gamma (= \cos \alpha)$	0.978		0.977				0.976						
Screen Size H-Width	48"	56"	64"	72"	80"	96"	120"	144"	160"	192"	216"	240"	
(4:3 Diagonal)	(60")	(70")	(80")	(90")	(100")	(120")	(150")	(180")	(200")	(240")	(270")	(300")	
A	inch	71.10	82.83	94.61	106.34	118.07	140.91	175.16	209.57	232.48	278.15	309.17	338.62
	mm	1806	2104	2403	2701	2999	3579	4449	5323	5905	7065	7853	8601

Note:

For screen sizes of 60 to 300 inches not indicated on the projection tables, use the formulas on page 1.

All calculations are with standard lens HD-18.

MultiSync® XG135LC Series Installation Guide

Cabinet Dimensions

9.1.97

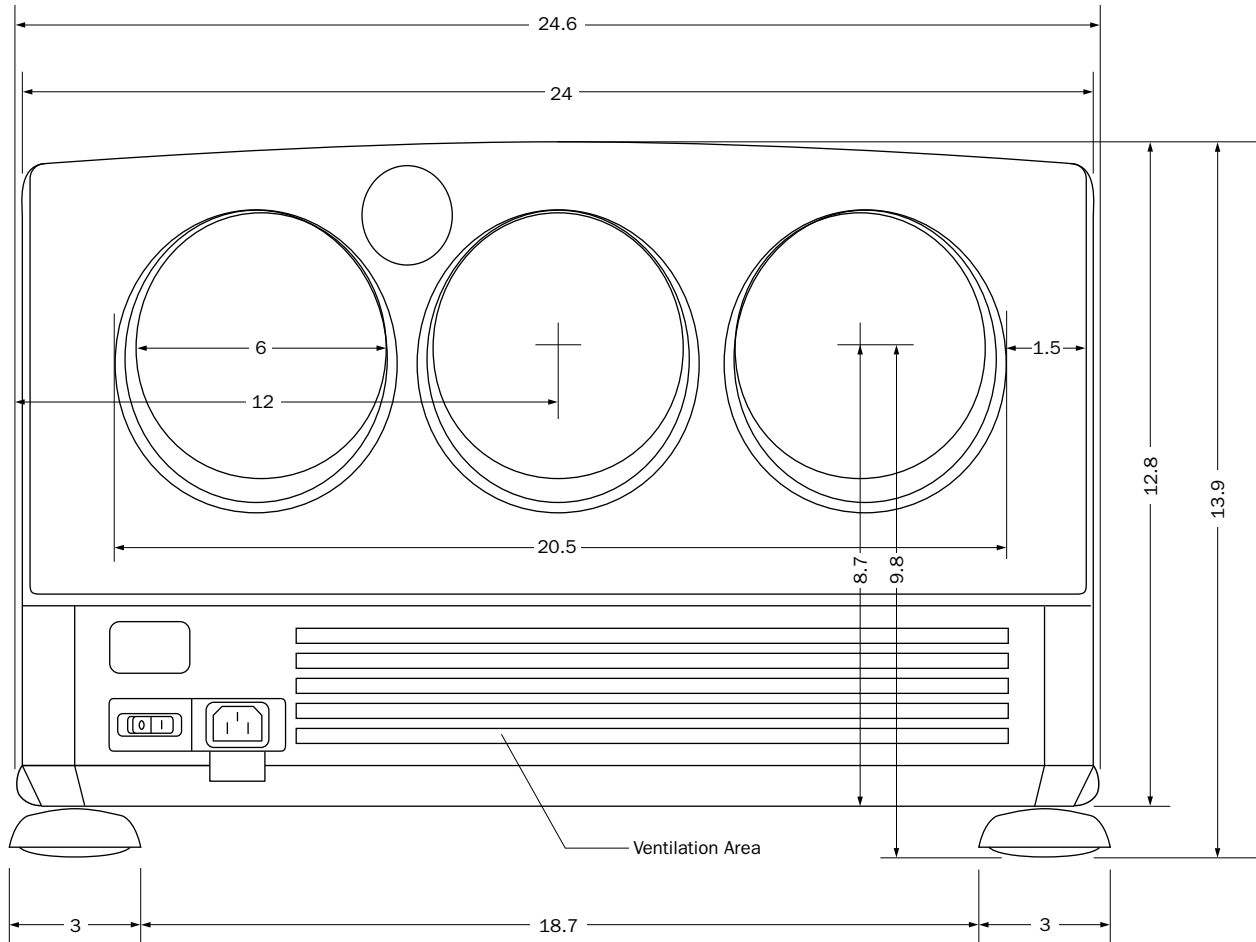

MultiSync® XG135LC Series Installation Guide

Projector Mounting Location

9.1.97

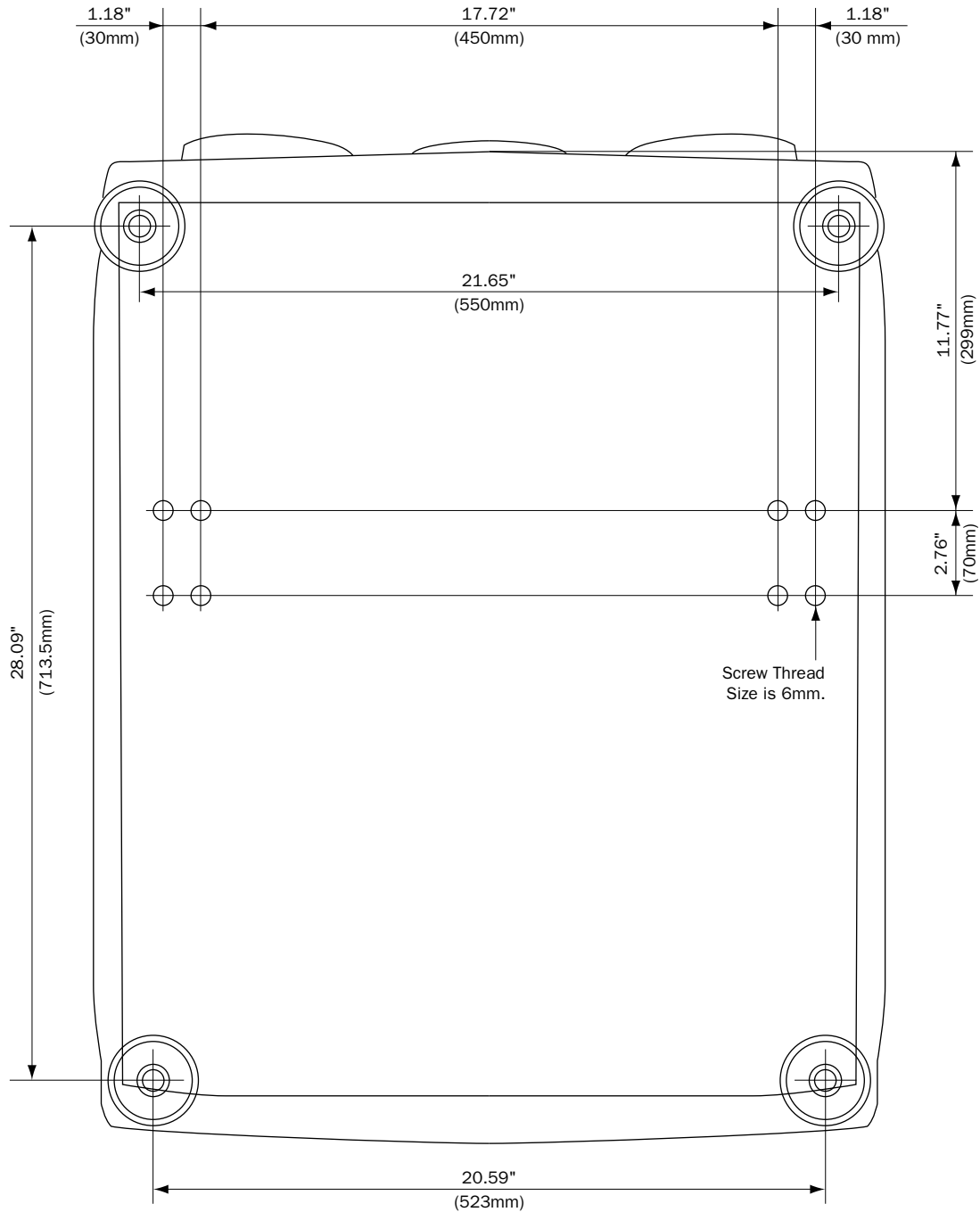

MultiSync® XG135LC Series Installation Guide

Deluxe Ceiling Mount and Bracket

9.1.97

Note:

Up and down tilt angle is $\pm 3^\circ$ from center position. Left to right swing is $\pm 3^\circ$ from center position.

Ceiling Mount

Mounting Brackets

